

Technical Specifications for the Step Lift 1000

Upper Landing Gates	Colour options from RAL range Glass gates Stainless steel gates Powered upper landing gates
Platform	Colour options from RAL range Glazing options
Call Station	Stainless steel or brass Bespoke platforms (available on request)
Safety Features	Pressure sensitive edges Bellows type mechanism guard Mechanically and electrically interlocking gates Slip resistant flooring
Adjacent Entry Option	Overall footprint: 1050 x 1835mm Useable platform: 800 x 1400mm
Individual Assessment	The lift shown in the diagram opposite, is a typical arrangement drawing only. Conformation of final dimensions and suitability of this lift will be determined by individual assessment.

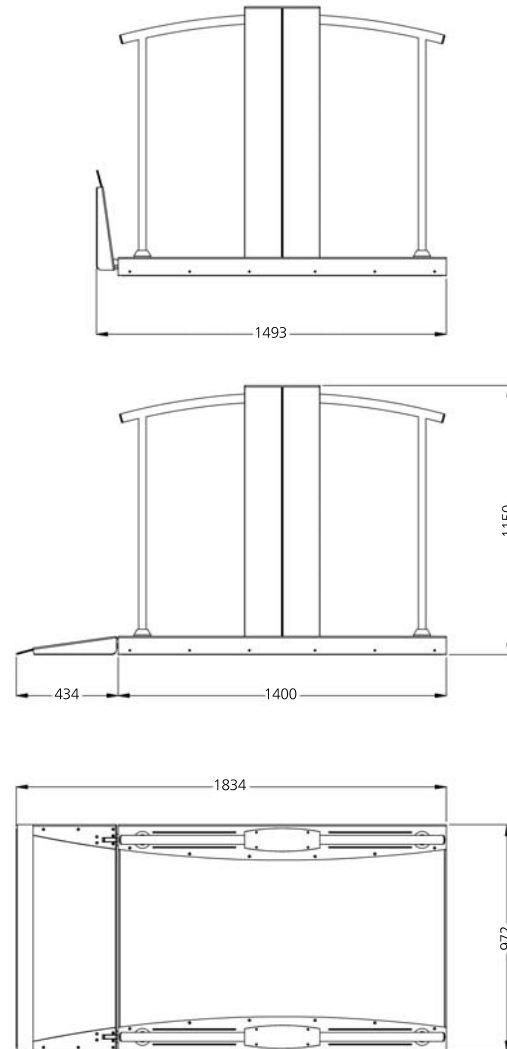

OPTIONAL EXTRAS

- Extended Width or 1100mm platform sizes
- Adjacent Entry configuration
- Choose from a variety of interlocking gates
- Automatic gate open and close
- Platform with gate and no ramp for smaller spaces
- Optional RAL colours and glass or Perspex side panels
- Recessed call stations (brass or stainless steel face plates)
- Vandal guards on call stations
- Customized control options

FOR FURTHER INFORMATION

For professional advice, a quotation or further details on any of our lifting systems please contact us at:

The Southborough Centre, Warehouse No.1, Draper Street, Southborough, Tunbridge Wells, Kent TN4 0PG

T: 01892 557530
F: 01892 557531
E: info@innovatelifts.com
W: www.innovatelifts.com

All information in this leaflet is correct at the time of printing. Innovate Lifting Systems reserve the right to make technical alterations due to product development.

Innovate
LIFTING SYSTEMS