

The Through-Floor Lift is a modern and unobtrusive solution providing access over 2 floors.

Designed using state-of-the-art lift technology, the Through-Floor Lift maximises the space available to you; when you are downstairs, the lift can be moved quietly and discreetly back upstairs, leaving you the full use of your living space.



Through Floor Lift

TRAVEL UP TO 4.2 M

SEATED, WHEELCHAIR AND SIDE-HUNG MODELS AVAILABLE

CHOICE OF 12 SIZES

CARRY UP TO 230 KG



STANDARD FEATURES

- ➔ 750 mm x 1100 mm internal car size
- ➔ Dual level travel
- ➔ Hydraulic or Traction Drive
- ➔ Vision panels and power door
- ➔ In car lighting, mirror and easy clean flooring
- ➔ Fully compliant with BS5900 and CE
- ➔ Emergency alarm and full safety edging on all areas



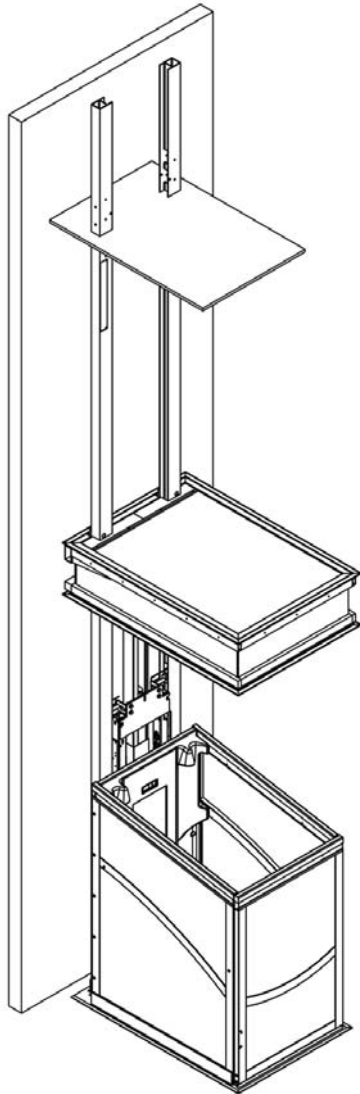

TECHNICAL SPECIFICATIONS for the Through-Floor Lift

| | |
|----------------------------|--|
| Location | Internal |
| Travel | Dual level |
| Power | Hydraulic or Traction |
| Maximum travel distance | 3.2 m with hydraulic drive 4.2 m with traction drive |
| Speed | 0.08 m per second with hydraulic drive 0.068 m per second with traction drive |
| First floor ceiling height | 2250 mm minimum |
| Access | Ramp |
| Fixing type | Free standing aluminium rails |

OPTIONAL FEATURES

- Range of seats: fixed, tip-up, perching and sliding
- In car telephone
- Remote controls
- Range of car sizes suitable for a broad range of wheel-chairs
- Customisation on request

FOR FURTHER INFORMATION

For professional advice, a quotation or further details on any of our lifting systems please contact us at:

Innovate Lifting Systems Ltd

The Southborough Centre
Warehouse No.1
Draper Street
Southborough
Tunbridge Wells
Kent TN4 0PG

T: 01892 557530

F: 01892 557531

E: info@innovatelifts.com

W: www.innovatelifts.com

