

The Residential lift is fully automatic, and exceptionally smooth running.

For multi-level access in your home, the Residential Lift is the perfect choice.

With all the expected benefits of an elevator, but with luxury styling and a choice of interior finishes to suit your home, it offers exceptional value for money without compromising on style and safety.



Residential Lifts

TRAVEL UP TO 15.2 M

CARRY UP TO 340 KG

INTERNAL USE ONLY

SUITABLE FOR WHEELCHAIRS

CAN INCORPORATE YOUR OWN DOORS

SAFETY FEATURES

- ➔ Emergency alarm and stop buttons
- ➔ Emergency battery powered lowering and manual lowering return the lift to base position in the event of power failure
- ➔ Automatic emergency lighting illuminates the cab so you will not be left in the dark
- ➔ Automatic battery recharging ensures availability of emergency battery back up systems

Luxury
styling



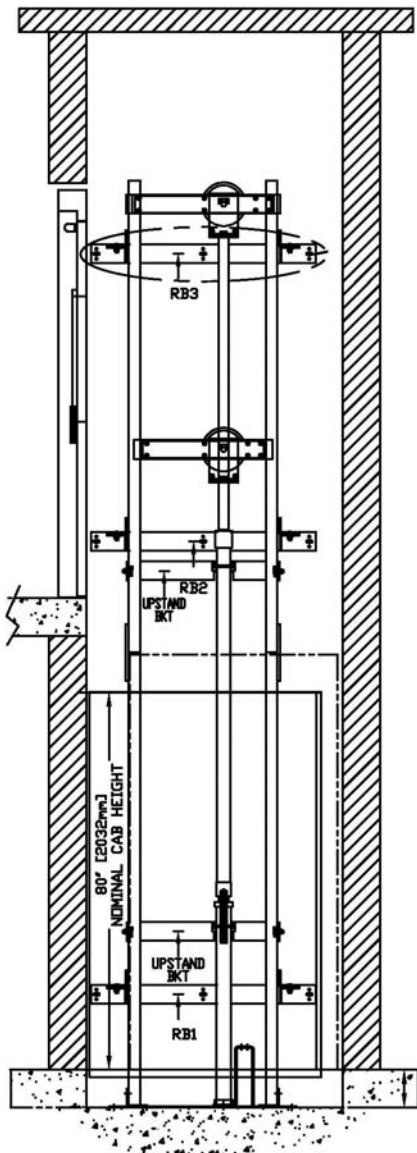

TECHNICAL SPECIFICATIONS for the Residential Lift Range

Rated Load	750 lbs (340 kg) or 1000 lbs (454 kg)
Rated Speed	36-fpm (0.18 m/s) nominal
Car Dimensions	36" W x 48" D (914 W x 1220 D mm)
Operation	Automatic
Gate Type	Horizontally collapsible, accordion style with 3 vision panels
Power Supply	220 Volts, Single Phase, 30 Amps
Travel Distance	50' (15.2 m) max
Levels Served	Maximum 5
Number of Openings	Two (2) Maximum
Lighting Supply	110 Volts, 1 Phase, 60 Cycle, 15 Amps
Jack Type	1:2 Cable Hydraulic
Pump Type	Submersible with Variable Speed Valve Leveling
Device Type	Magnetic

OPTIONAL EXTRAS

- Stainless steel surface mounted fixtures
- Brass surface mounted fixtures
- Automatic door openers
- Various styles of interlocks for hoistway doors
- Doors to suit your decor can be added so your lift will blend into its surroundings
- Choose from an extensive range of interior finishes including: raised panels, oak veneers and cylindrical brass or stainless steel handrail
- Additional finishing options include: clear or brass adonised cab trim, recessed brass down lights, brass call stations, brass cab operating panel and designer operating panel
- Telephone jack and cabinet (telephone not supplied)
- A number of cab configurations are available to suit numerous environments
- Custom cab sizes available

FOR FURTHER INFORMATION

For professional advice, a quotation or further details on any of our lifting systems please contact us at:

Innovate Lifting Systems Ltd

The Southborough Centre
Warehouse No.1
Draper Street
Southborough
Tunbridge Wells
Kent TN4 0PG

T: 01892 557530
F: 01892 557531

E: info@innovatelifts.com
W: www.innovatelifts.com